

FABL4275 | 10W~95 W | Weight: 340g (APPROX)

Rated Voltage from 6V to 30VDC, Speed, torque, etc. free customization.

·典型应用 Typical Use

个人护理(Personal Care)
家用电器(Home Application)
电动工具(Power Tools)
商业设备(Business Equipment)
医疗器械(Medical Apparatus)

·连接端口 Connector Interface

Number	Function
1	VCC
2	FG
3	CW/CCW
4	GND
5	PWM
6	BRAKE

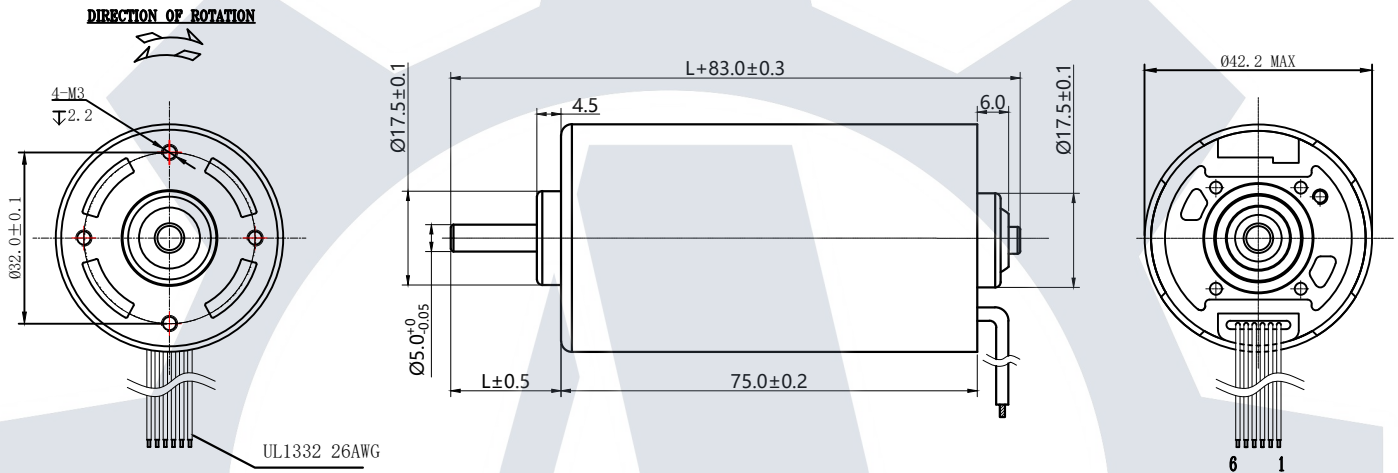
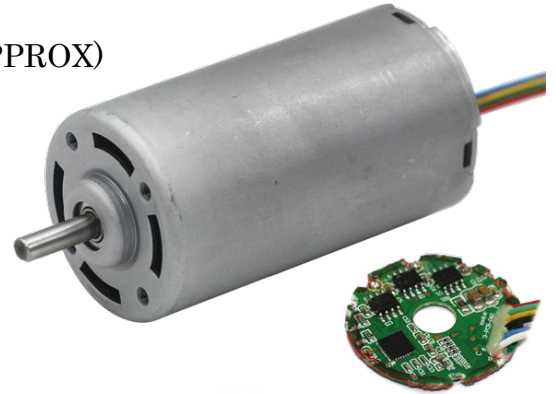

Shaft Length "L" can be customized charge-free, shaft shape can be also customized accordingly.

UNIT:MM

MODEL	VOLTAGE		NO LOAD		AT MAXIMUM EFFICIENCY				STALL	
	OPERATING RANGE	RATED	SPEED	CURRENT	SPEED	CURRENT	TORQUE	OUTPUT	TORQUE	CURRENT
			r/min	A	r/min	A	g. cm	W	g. cm	A
FABL4275-V1	8V~26V	12V	2813	0.34	2292	2.29	867.5	20.4	4671.6	5
FABL4275-V2	8V~26V	18V	3790	0.32	2930	2	857.3	25.8	3753.5	5
FABL4275-V3	8V~26V	24V	4996	0.28	3368	2.23	1000.2	40.6	4773.8	5

FABL4275-V1 12V

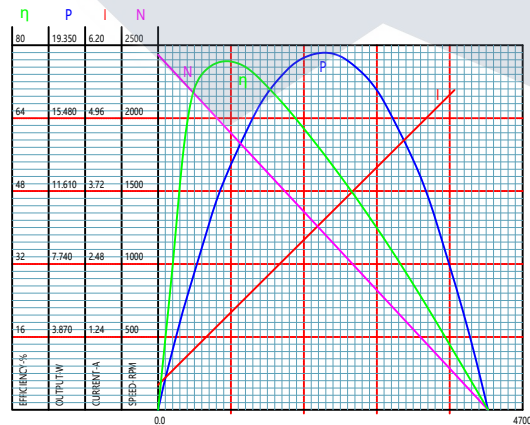

TORQUE (g. cm)

FABL4275-V3 24V

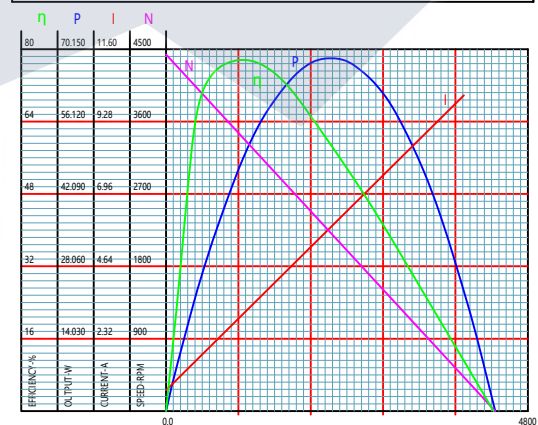

TORQUE (g. cm)